

**N-沟道功率 MOS 管/ N-CHANNEL POWER MOSFET**

**SIF4N65F**

- 特点：导通电阻低 开关速度快 输入阻抗高 符合RoHS规范
- FEATURES: ■LOW ON-RESISTANCE ■FAST SWITCHING ■HIGH INPUT RESISTANCE ■RoHS COMPLIANT
- 应用：电子镇流器 电子变压器 开关电源
- APPLICATION: ■ELECTRONIC BALLAST■ELECTRONIC TRANSFORMER■SWITCH MODE POWER SUPPLY

●最大额定值 (Tc=25°C)

●Absolute Maximum Ratings (Tc=25°C)

TO-220/220FPL/262/263

参数 PARAMETER	符号 SYMBOL	额定值 VALUE	单位 UNIT
漏-源电压 Drain-source Voltage	V <sub>DS</sub>	650	V
栅-源电压 gate-source Voltage	V <sub>GS</sub>	±30	V
漏极电流 Continuous Drain Current TC=25°C	I <sub>D</sub>	4.0	A
漏极电流 Continuous Drain Current TC=100°C	I <sub>D</sub>	2.5	A
最大脉冲电流 Drain Current – Pulsed ①	I <sub>DM</sub>	16	A
耗散功率 Power Dissipation	P <sub>tot</sub>	TO-220:104	W
		TO-220FPL:36	
		TO-262/263:104	
最高结温 Junction Temperature	T <sub>j</sub>	150	°C
存储温度 Storage Temperature	T <sub>STG</sub>	-55-150	°C
单脉冲雪崩能量 Single Pulse Avalanche Energy②	E <sub>AS</sub>	128	mJ

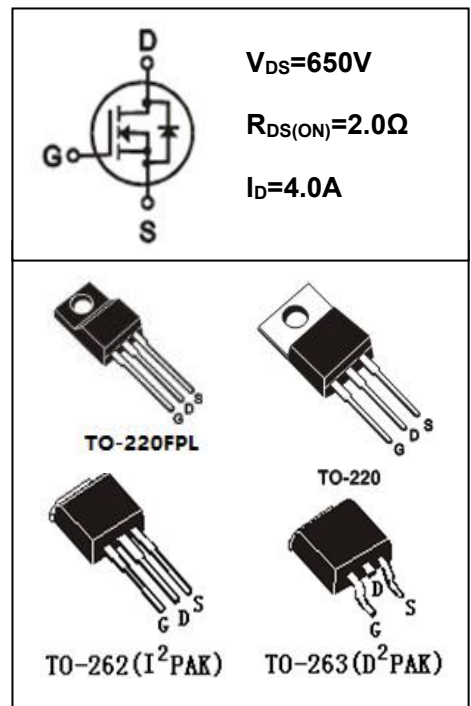

●电特性 (Tc=25°C)

●Electronic Characteristics (Tc=25°C)

参数 PARAMETER	符号 SYMBOL	测试条件 TEST CONDITION	最小值 MIN	典型值 TYP	最大值 MAX	单位 UNIT
漏-源击穿电压 Drain-source Breakdown Voltage	BV <sub>DSS</sub>	V <sub>GS</sub> =0V, I <sub>D</sub> =250μA	650			V
击穿电压温度系数 Breakdown Voltage Temperature Coefficient	ΔBV <sub>DSS</sub> /ΔT <sub>j</sub>	I <sub>D</sub> =250uA, Referenced to 25°C		0.6		V/°C
栅极开启电压 Gate Threshold Voltage	V <sub>GS(TH)</sub>	V <sub>GS</sub> =V <sub>DS</sub> , I <sub>D</sub> =250μA	2.0		4.0	V
漏-源漏电流 Drain-source Leakage Current	I <sub>DSS</sub>	V <sub>DS</sub> = 650V, V <sub>GS</sub> = 0V, T <sub>j</sub> = 25°C			25	μA
		V <sub>DS</sub> = 480V, V <sub>GS</sub> = 0V, T <sub>j</sub> = 125°C			250	μA
跨导 Forward Transconductance	g <sub>fs</sub>	V <sub>DS</sub> = 40V, I <sub>D</sub> = 2.0A ③		2.5		S

●订单信息/ORDERING INFORMATION:

包装形式/PACKING	订货编码/ORDERING CODE	
	普通塑封料/ Normal Package Material	无卤塑封料/Halogen Free
TO-220 条管装/TUBE PACKING	SIF4N65F TO-220-TU	SIF4N65F TO-220-TU-HF
TO-220FPL 条管装/TUBE PACKING	SIF4N65F TO-220FPL-TU	SIF4N65F TO-220FPL-TU-HF
TO-262 或 263 条管装/TUBE PACKING	SIF4N65F TO-262-TU 或 SIF4N65F TO-263-TU	SIF4N65F TO-262-TU-HF 或 SIF4N65F TO-263-TU-HF
TO-263 编带装/TAPE & REEL PACKING	SIF4N65F TO-263-TR	SIF4N65F TO-263-TR-HF

N-沟道功率 MOS 管/ N-CHANNEL POWER MOSFET

SIF4N65F

参数 PARAMETER	符号 SYMBOL	测试条件 TEST CONDITION	最小值 MIN	典型值 TYP	最大值 MAX	单位 UNIT
栅极漏电流 Gate-body Leakage Current ( $V_{DS} = 0$ )	$I_{GSS}$	$V_{GS} = \pm 30V$			$\pm 100$	nA
漏-源导通电阻 Static Drain-source On Resistance	$R_{DS(ON)}$	$V_{GS} = 10V, I_D = 2.0A$ ③		2.0	2.5	$\Omega$
输入电容 Input Capacitance	$C_{iss}$	$V_{GS} = 0V, V_{DS} = 25V$ $F = 1.0MHz$		590	650	pF
输出电容 Output Capacitance	$C_{oss}$			48	55	
反向传输电容 Reverse transfer Capacitance	$C_{rss}$			5	12	
关断延迟 Turn -Off Delay Time	$T_d(off)$	$V_{DD} = 300V, I_D = 4.0A$ $R_G = 25\Omega$ ③		25		ns
栅极电荷 Total Gate Charge	$Q_g$	$I_D = 4.0A, V_{DS} = 520V$ $V_{GS} = 10V$ ③		13.7		nC
栅源电荷 Gate-to-Source Charge	$Q_{gs}$			2.9		nC
栅漏电荷 Gate-to-Drain Charge	$Q_{gd}$			4.6		nC
二极管正向电流 Continuous Diode Forward Current	$I_S$				4.0	A
二极管正向压降 Diode Forward Voltage	$V_{SD}$	$T_j = 25^\circ C, I_S = 4.0A$ $V_{GS} = 0V$ ③			1.4	V
反向恢复时间 Reverse Recovery Time	$t_{rr}$	$T_j = 25^\circ C, I_f = 4.0A$ $di/dt = 100A/\mu s$ ③		390		ns
反向恢复电荷 Reverse Recovery Charge	$Q_{rr}$			1.5		$\mu C$

●热特性

●Thermal Characteristics

参数 PARAMETER	符号 SYMBOL	最大值 MAX			单位 UNIT
		TO-220	TO-220FPL	TO-262/263	
热阻结-壳 Thermal Resistance Junction-case	$R_{thJC}$	1.20	3.47	1.20	$^\circ C/W$
热阻结-环境 Thermal Resistance Junction-ambient	$R_{thJA}$	62.5	62.5	62.5	$^\circ C/W$

注释(Notes):

- ① 脉冲宽度：以最高结温为限制  
Repetitive rating: Pulse width limited by maximum junction temperature
- ② 初始结温=25 $^\circ C$ ,  $V_{DD} = 50V$ ,  $L = 25mH$ ,  $R_G = 25\Omega$ ,  $I_{AS} = 4.0A$   
Starting  $T_j = 25^\circ C$ ,  $V_{DD} = 50V$ ,  $L = 25mH$ ,  $R_G = 25\Omega$ ,  $I_{AS} = 4.0A$
- ③ 脉冲测试：脉冲宽度 $\leq 300\mu s$ ，占空比 $\leq 2\%$   
Pulse Test : Pulse width  $\leq 300\mu s$ , Duty cycle  $\leq 2\%$

N-沟道功率 MOS 管/ N-CHANNEL POWER MOSFET

SIF4N65F

● 特性曲线



图 1 输出特性曲线, Tc=25°C

Fig1 Typical Output Characteristics, Tc=25°C

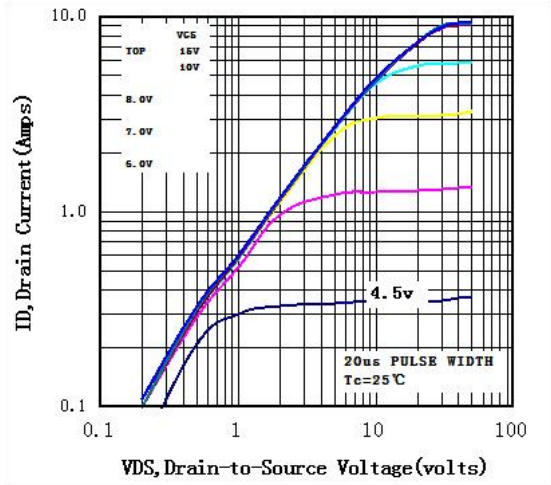

图 2 输出特性曲线, Tc=150°C

Fig2 Typical Output Characteristics, Tc=150°C

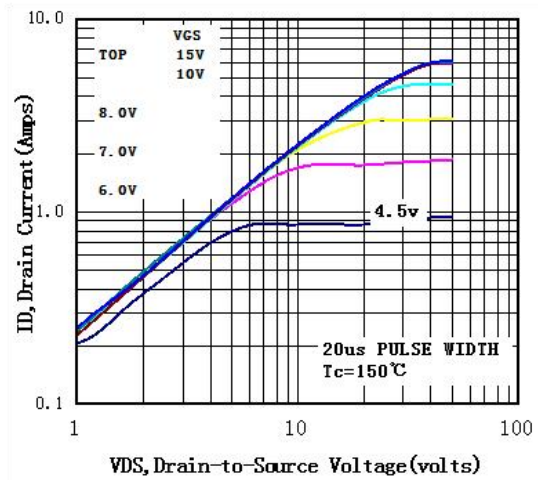

图 3 归一化导通电阻与温度曲线

Fig3 Normalized Resistance Vs. Temperature

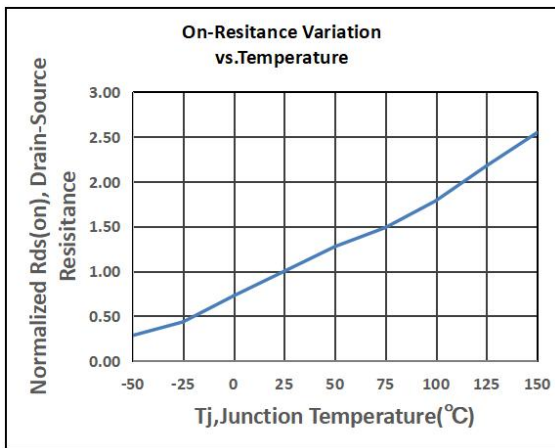

图 4 二极管正向电压曲线

Fig4 Typical Source-Drain Diode Forward Voltage

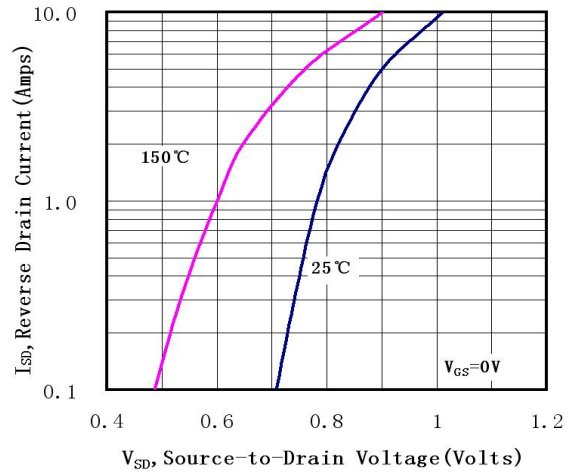

图 5 最大漏极电流与壳温曲线

Fig5 Maximum Drain Current Vs. Case Temperature

N-沟道功率 MOS 管/ N-CHANNEL POWER MOSFET

SIF4N65F

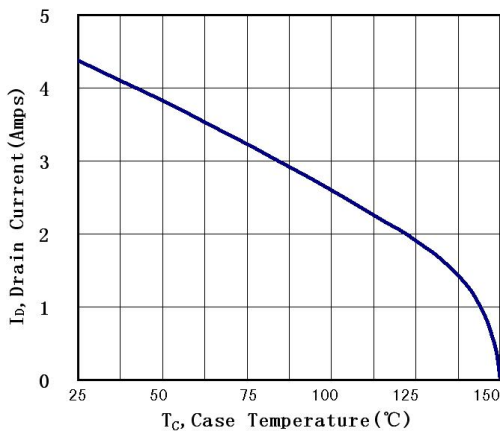
● 特性曲线



图 6-1 SIF4N65F(TO-220)

最大安全工作区曲线

Fig6-1 Maximum Safe Operating Area

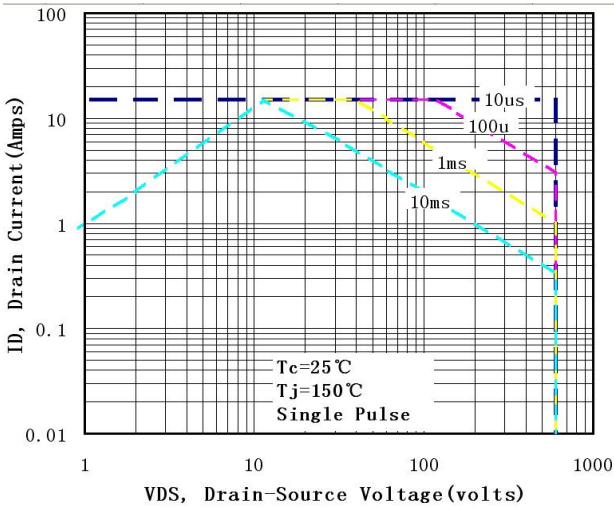

图 6-2 SIF4N65F(TO-220FPL)

最大安全工作区曲线

Fig6-2 Maximum Safe Operating Area

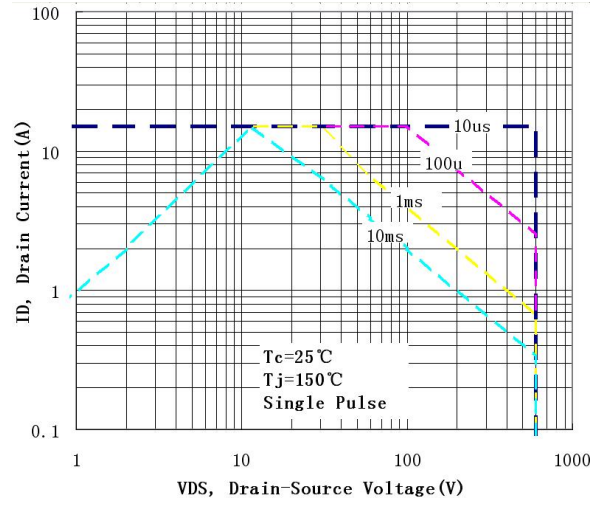

图 6-3 SIF4N65F(TO-262&263)

最大安全工作区曲线

Fig6-3 Maximum Safe Operating Area

## TO-220 封装机械尺寸 TO-220 MECHANICAL DATA

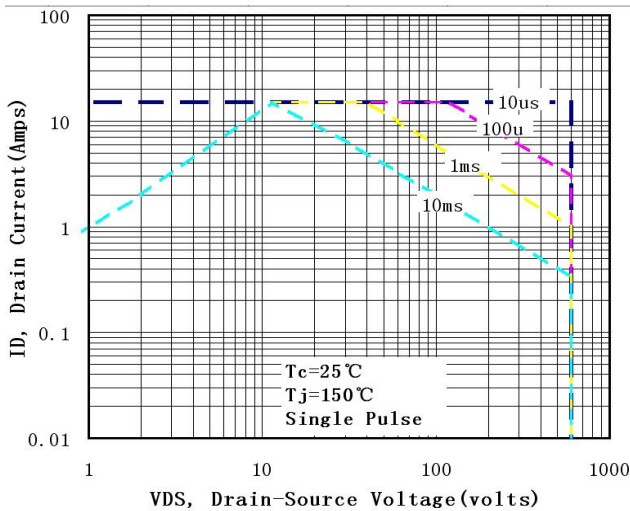
单位：毫米/UNIT: mm

符号 SYMBOL	最小值 min	典型值 nom	最大值 max	符号 SYMBOL	最小值 min	典型值 nom	最大值 max
A	4.30		4.70	E	9.80		10.30
B	1.20		1.50	e		2.54	
B1	1.00		1.40	F	1.20		1.40
b1	0.65		1.00	L	12.50		13.50
c	0.35		0.75	L1	2.60		3.50
D	15.00		16.00	Q	2.50		3.00
D1	5.90		6.90	Q1	2.00		3.00
				$\phi P$	3.50		3.90

SIC

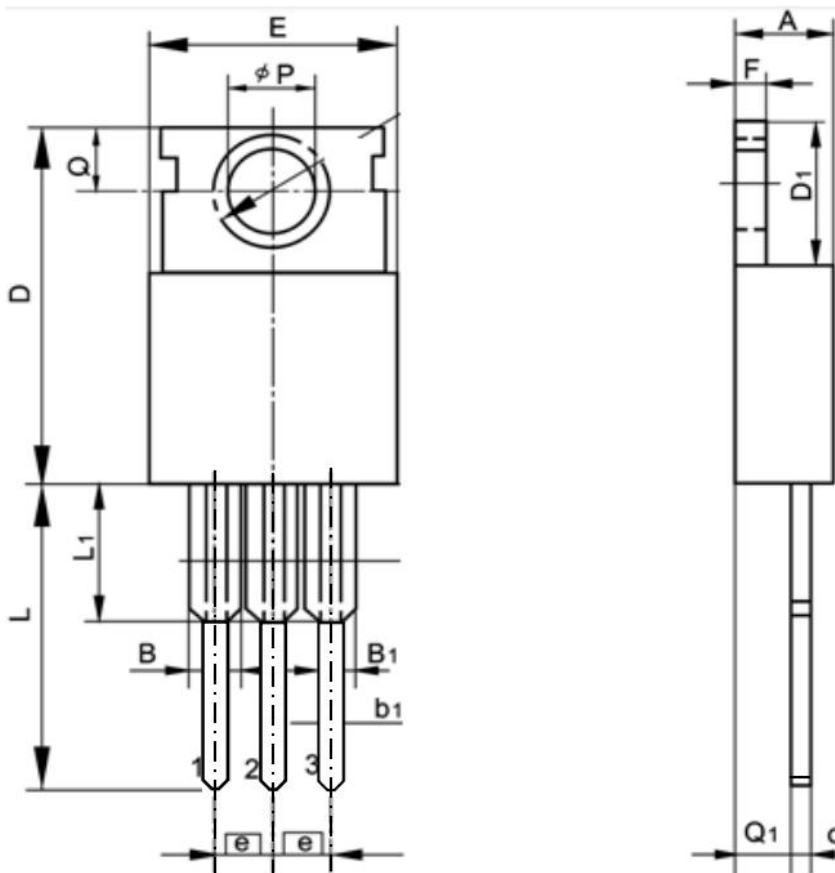

## TO-220FPL 封装机械尺寸 TO-220FPL MECHANICAL DATA

单位:毫米/UNIT: mm

符号 SYMBOL	最小值 min	典型值 nom	最大值 max	符号 SYMBOL	最小值 min	典型值 nom	最大值 max
A	9.90		10.36	a	1.08		1.48
B	15.40		16.40	a1	0.70		0.90
B1	3.05		3.55	E	2.34		2.75
C	4.40		5.00	C1	2.25		2.85
c	0.40		0.60	C2	2.45		3.05
b	12.40		13.50	R	2.90		3.35
<b>b1</b>	<b>2.60</b>		<b>3.60</b>				

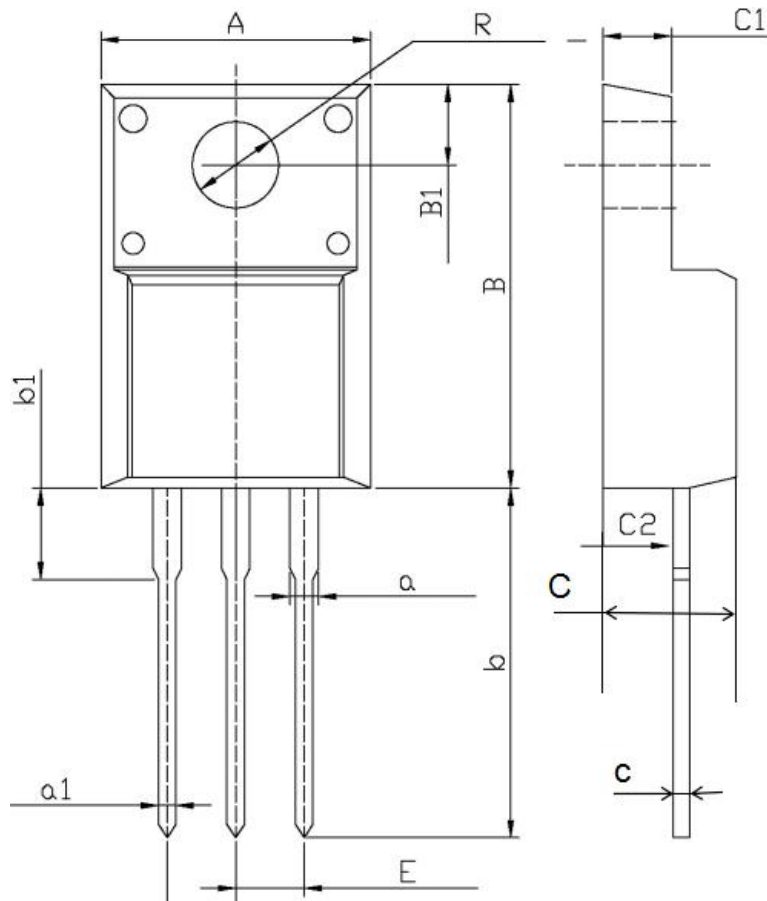

## TO-262 封装机械尺寸 TO-262 MECHANICAL DATA

单位：毫米/UNIT: mm

符号 SYMBOL	最小值 min	典型值 nom	最大值 max	符号 SYMBOL	最小值 min	典型值 nom	最大值 max
A	3.80		4.80	e		2.54	
A1	2.00		2.80	e1			5.30
b	0.60		1.00	E	9.90		10.70
b1	1.20		1.40	L	12.50		14.50
c	0.40		0.70	L1	0.80	1.00	1.20
c2	1.10		1.40	L2			1.50
D			9.60				

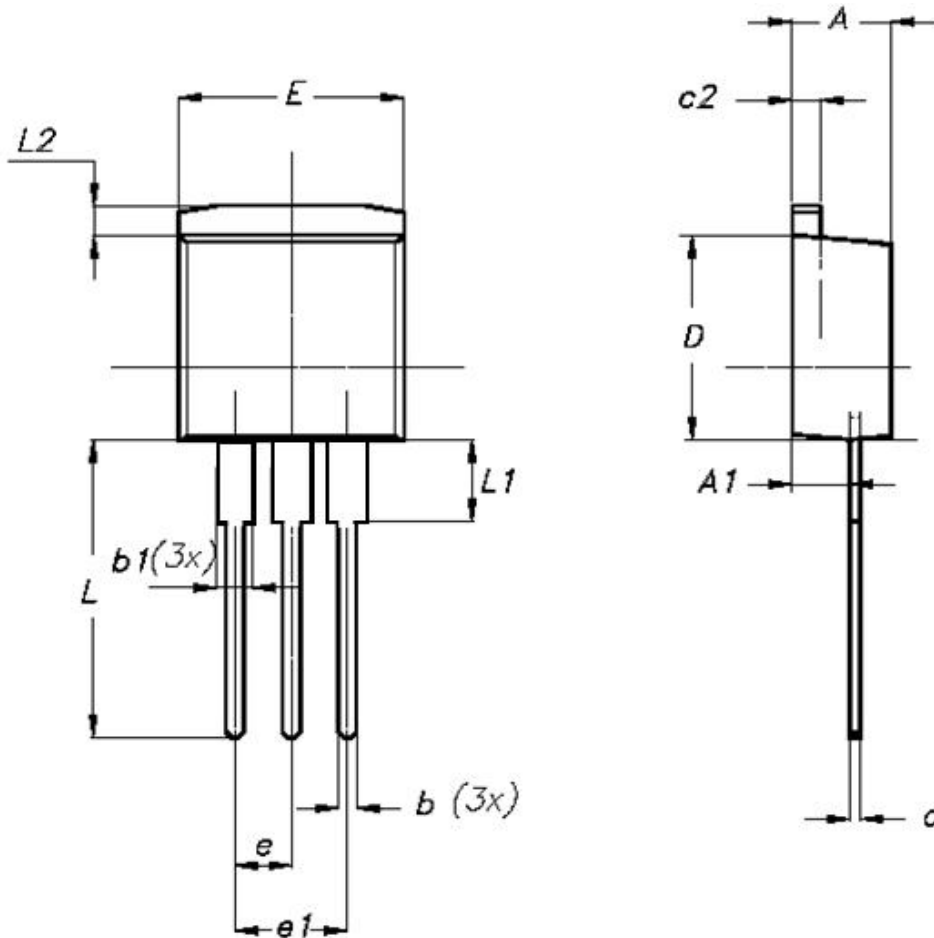

## TO-263 封装机械尺寸

### TO-263(D2PAK) MECHANICAL DATA

单位：毫米/UNIT: mm

符号 SYMBOL	最小值 min	典型值 nom	最大值 max	符号 SYMBOL	最小值 min	典型值 nom	最大值 max
A	4.42		4.72	E	8.99		9.29
B	1.22		1.32	e1	2.44		2.64
b	0.76		0.86	e2	4.98		5.18
b1	1.22		1.32	L1	15.19		15.79
b2	0.33		0.43	L2	2.29		2.79
C	1.22		1.32	L3	1.30		1.75
D	9.95		10.25				

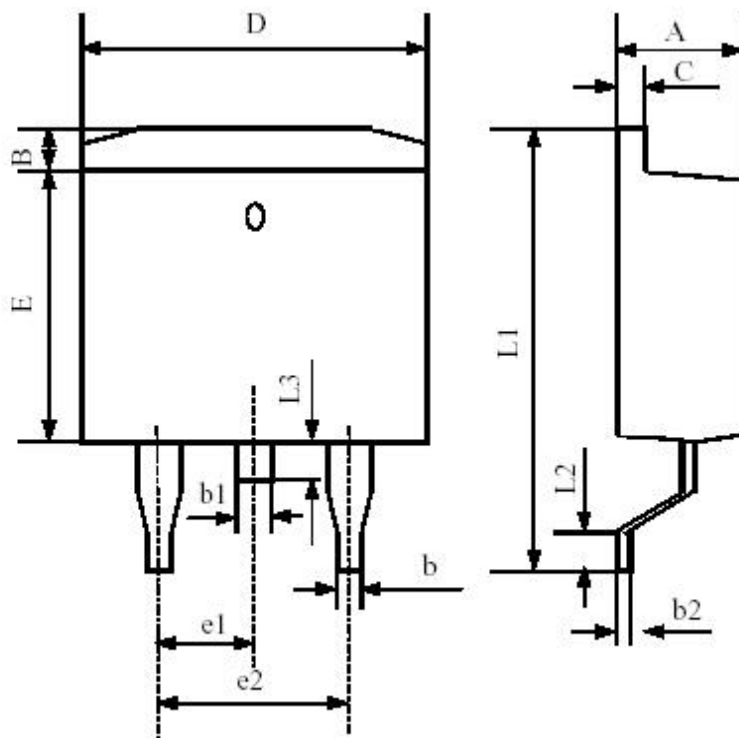



## TO-263 编带规格尺寸 TO-263 TAPE AND REEL DATA

单位:毫米/UNIT: mm

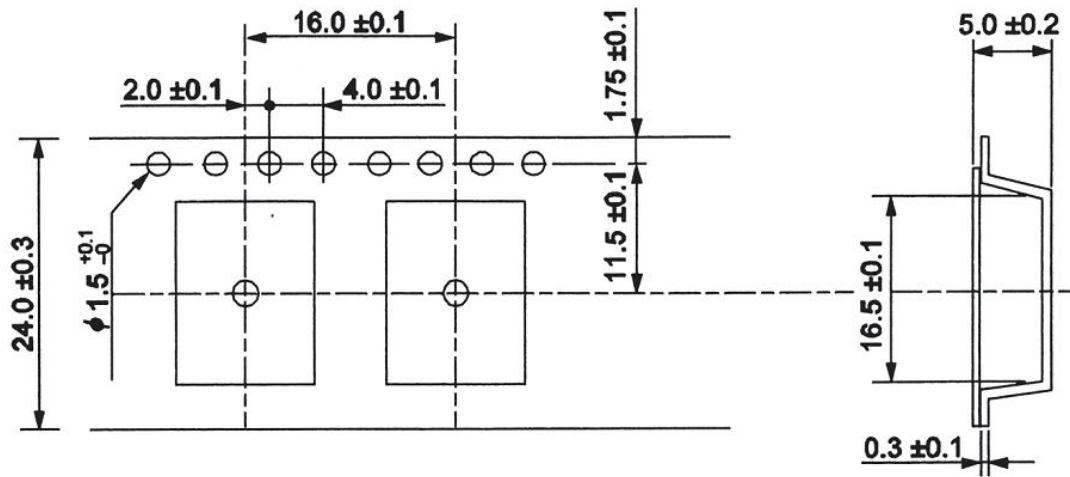

使用供带方向/USER DIRECTION OF FEED

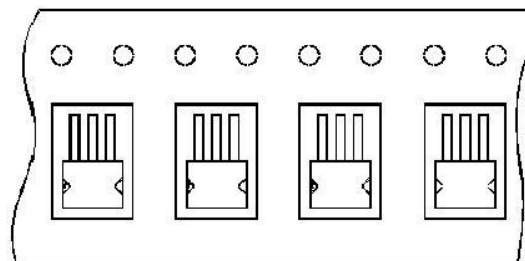

编带器件定位示意图/UNIT ORIENTATION